

AS4V99V

STANDARD MATERIALS AND CONSTRUCTION

FRAME: .081" thick (nominal) extruded aluminum, 6063-T52/T6 alloy.

BLADE: .081" thick (nominal) extruded aluminum, 6063-T52/T6 alloy.
Blades approximately 3" on centers.

LOUVER FACE: All surfaces are flush, with jambs contained within the head and sill.

SCREEN: (When indicated.)

1/2" flattened aluminum (.051" thick),

-or- 1/2" sq. mesh, intermediate double-crimped aluminum wire, .063" dia.,

-or- 19/16 mesh, .011" dia. aluminum wire, insect screen.

FINISH: Mill

OPTIONS

Finish - Baked Enamel, Kynar, Anodize

NOTES

1. Nominal deductions will be made to the opening size given.
2. Approximate shipping weight is 5.0 lbs./sq.ft.

LOUVER SIZES

Min Panel	Max Single Panel
12"W x 12"H	96"W x 60"H

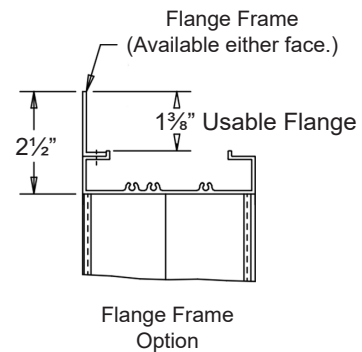
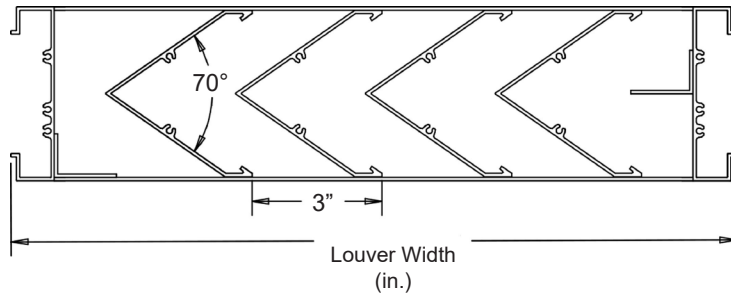
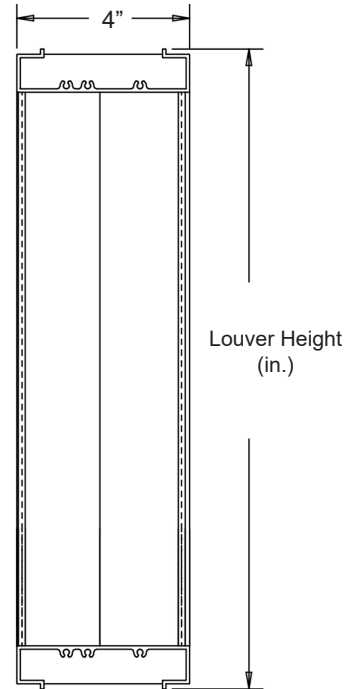

In the interest of product development, Airline Louvers reserves the right to make changes without notice.

											
Item #	Qty	Width	Height	Width	Height	Mullion	Type	Location			
		Opening Size		Louver Size			Screens			Union Made	
Arch. / Eng. :						EDR:		ECN:		Job:	
Contractor:											
Project:						Date:		DWN:		DWG:	

AS4V99V

PERFORMANCE DATA

Pressure Drop: .50 in. w.g. at 1000 fpm (intake)

Free Area: 6.22 sq.ft. = 38.9% for 48"W x 48"H sample tested in accordance with AMCA Standard 500-L.

Beginning Point of Water Penetration: 848 fpm

Ratings do not include effects of a screen.

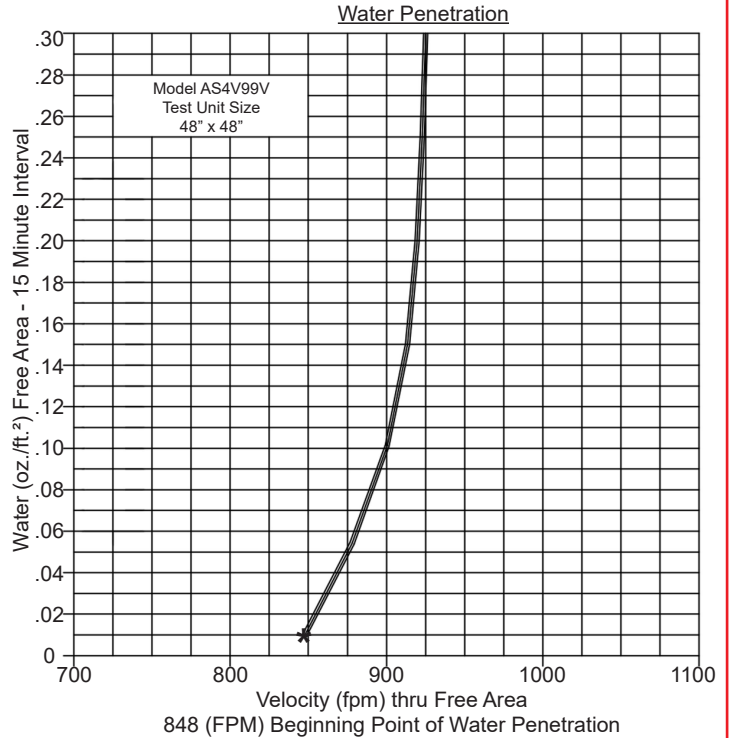
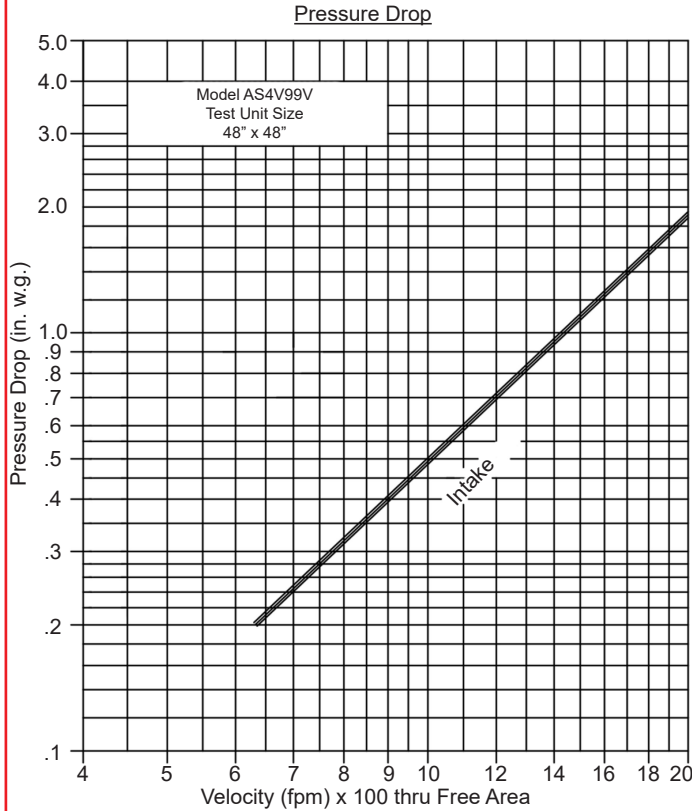

Intake air converted to standard air density.
Tested to AMCA Standard 500-L, Figure 5.5.

		Free Area (sq.ft.)								
		Width (in.)								
		12"	18"	24"	30"	36"	42"	48"	54"	60"
Height (in.)	12"	.27	.40	.53	.67	.80	.93	1.07	1.20	1.33
	24"	.70	1.04	1.39	1.74	2.09	2.43	2.78	3.13	3.48
	36"	1.13	1.69	2.25	2.81	3.38	3.94	4.50	5.06	5.63
	48"	1.55	2.33	3.11	3.89	4.66	5.44	6.22	6.99	7.77
	60"	1.98	2.98	3.97	4.96	5.95	6.94	7.93	8.93	9.92
	72"	2.41	3.62	4.83	6.03	7.24	8.45	9.65	10.86	12.07
	84"	2.84	4.26	5.68	7.11	8.53	9.95	11.37	12.79	14.21
	96"	3.27	4.91	6.54	8.18	9.82	11.45	13.09	14.72	16.36